

Support bars

Installation and usage instructions

EN

Stützleisten

Montage- und Gebrauchsanleitung

DE

Barres de support

Instructions de montage et mode d'emploi

FR

Barras de soporte

Instrucciones de montaje y uso

ES

Barre di supporto

Istruzioni di montaggio e d'uso

IT

Please consult the website for
instructions in the languages:
NL-SV-DA-NO-FI-PT



KIT SUPPORT BAR

98656B682



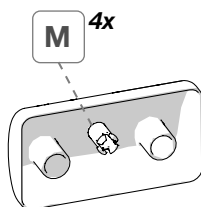
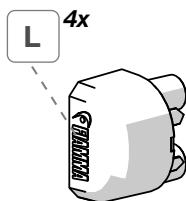
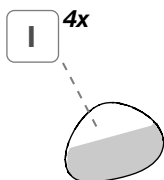
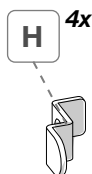
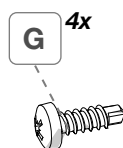
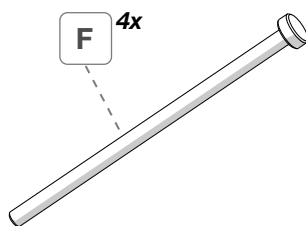
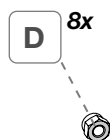
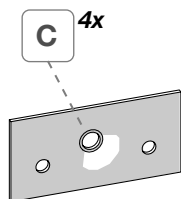
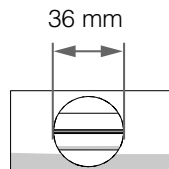
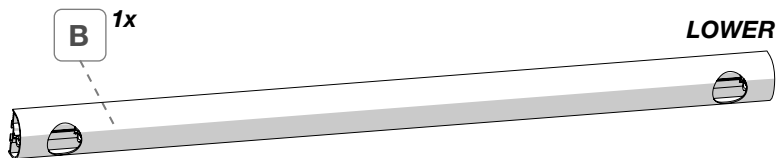
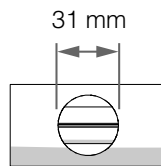
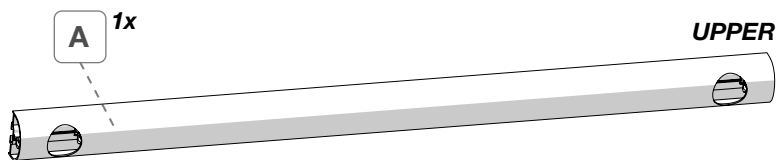

Package contents / Verpackungsinhalt / Contenu de l'emballage / Contenido del embalaje / Contenuto dell'imballo

p. 2

Installation instructions / Montageanleitung / Instructions de montage / Instrucciones de montaje / Istruzioni di montaggio

p. 3

Safety instructions / Sicherheitshinweise / Consignes de sécurité / Instrucciones de seguridad / Avvertenze di sicurezza

p. 6

Warranty / Garantie / Garantie / Garantía / Garanzia

p. 7

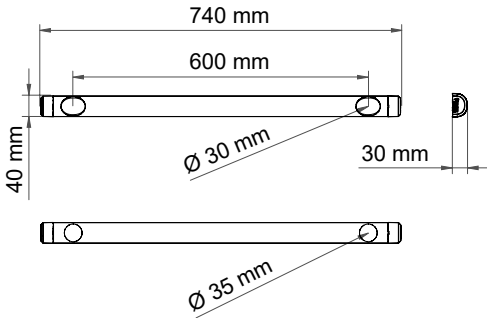

EN Check that nothing has been damaged or deformed during transport. In the event of doubts or questions concerning the installation, use or limitations of the product, contact the dealer. **We recommend that the installation is carried out by qualified personnel and in compliance with current local regulations.**

DE Bitte kontrollieren Sie, dass alle Einzelteile einwandfrei sind und nicht während dem Transport beschädigt wurden. Im Zweifelsfall oder bei Fragen zur Montage, Verwendung oder zu Einschränkungen des Produkts wenden Sie sich bitte an Ihren Händler. **Wir empfehlen die Anbringung durch Fachpersonal in Übereinstimmung mit den geltenden lokalen Vorschriften vornehmen zu lassen.**

FR Contrôler le contenu du colis et vérifier qu'aucune pièce n'ait été cassée ou déformée durant le transport. En cas de doutes ou de questions relatives à l'installation, l'utilisation du produit, contactez votre concessionnaire. **L'installation doit être réalisée par des personnes dûment qualifiées et conformément aux normes en vigueur dans le pays d'installation.**

ES Controlar que ningún detalle se haya roto o deformado durante el transporte. En caso de dudas o si tiene alguna pregunta sobre el montaje, uso y limitaciones del producto, póngase en contacto con el distribuidor. **Recomendamos que la instalación se realice por personal cualificado en conformidad con las regulaciones locales.**

IT Controllare che nessun particolare sia rotto o deformato a causa di errori di trasporto. In caso di dubbi o domande relative al montaggio, utilizzo e limiti del prodotto, contattare il rivenditore. **Consigliamo di far eseguire l'installazione da parte di personale qualificato ed in conformità alle vigenti normative locali.**

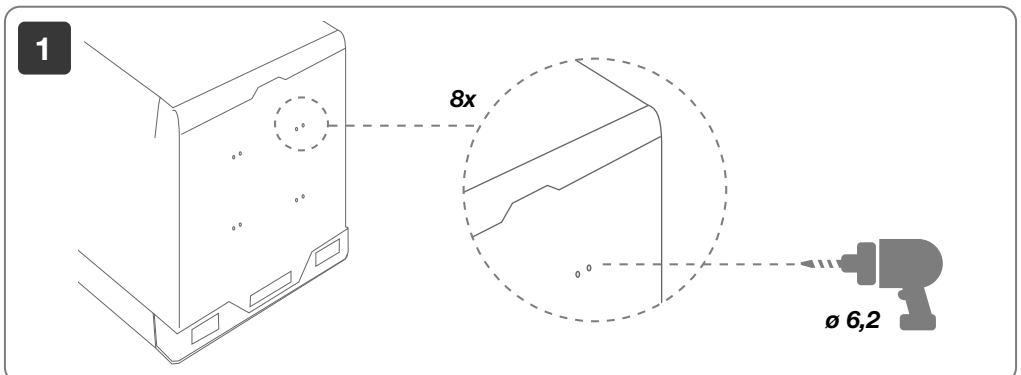

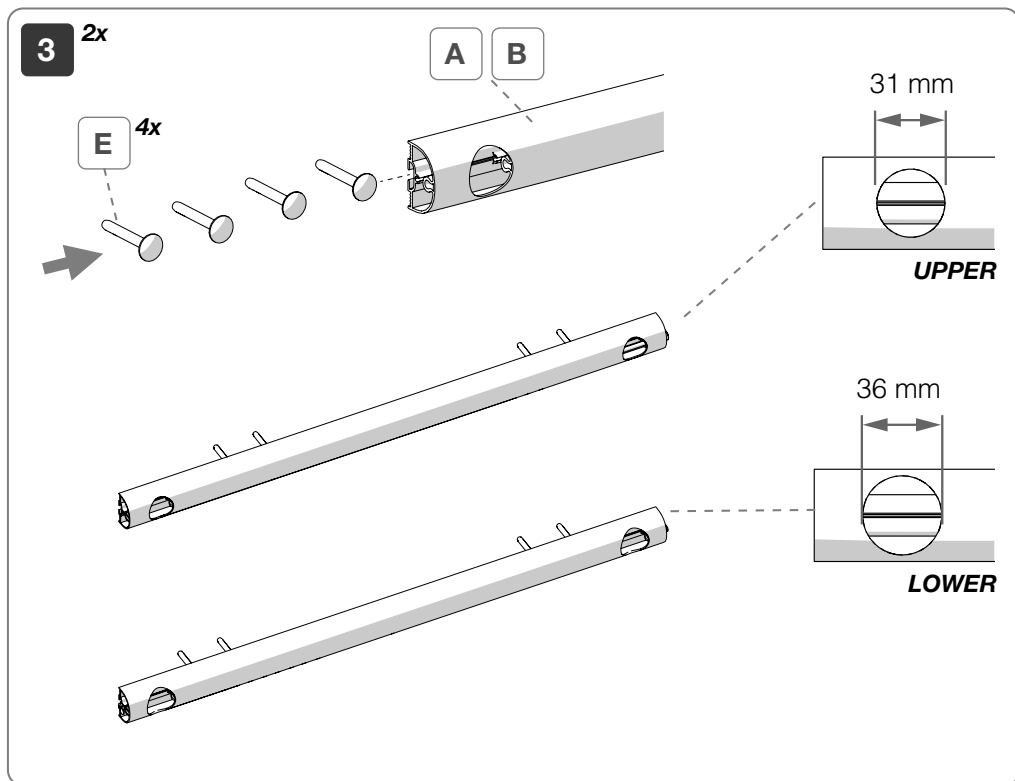
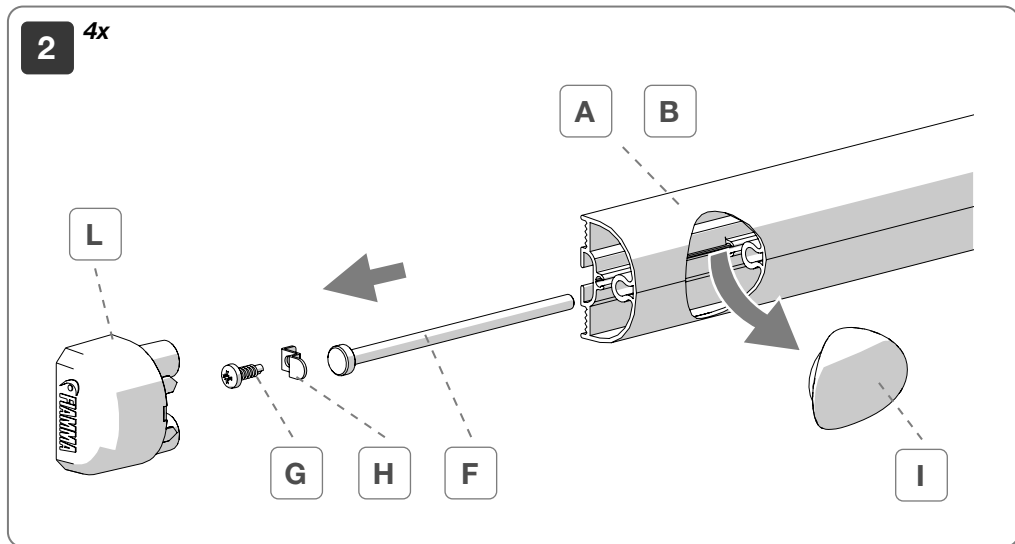



4

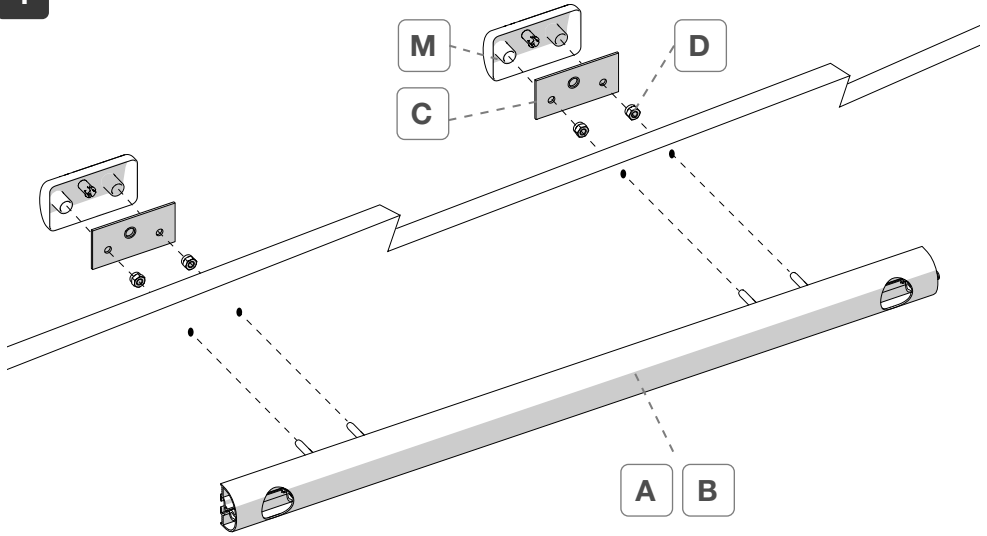

5 UPPER

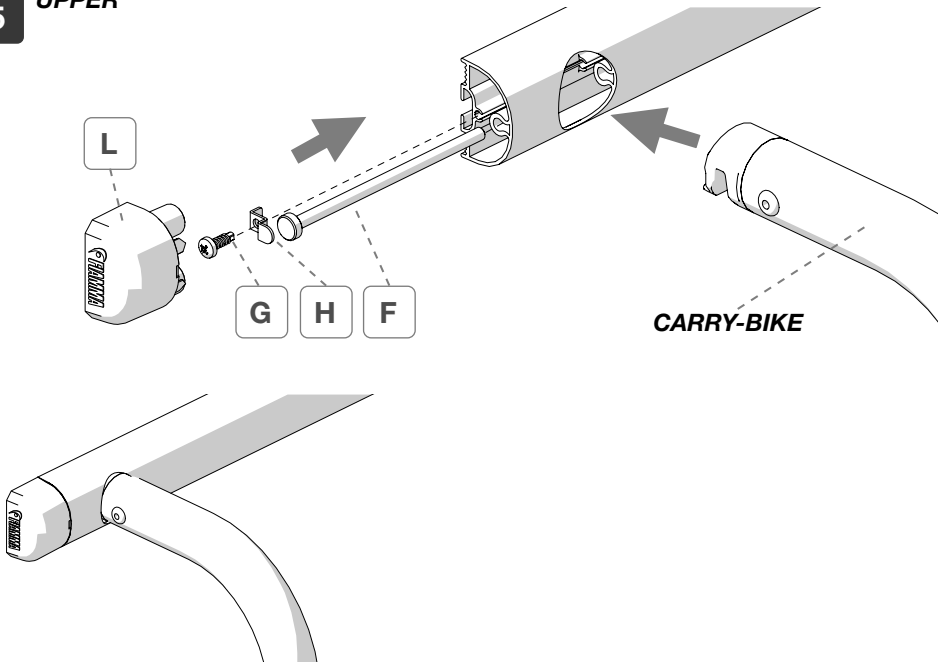

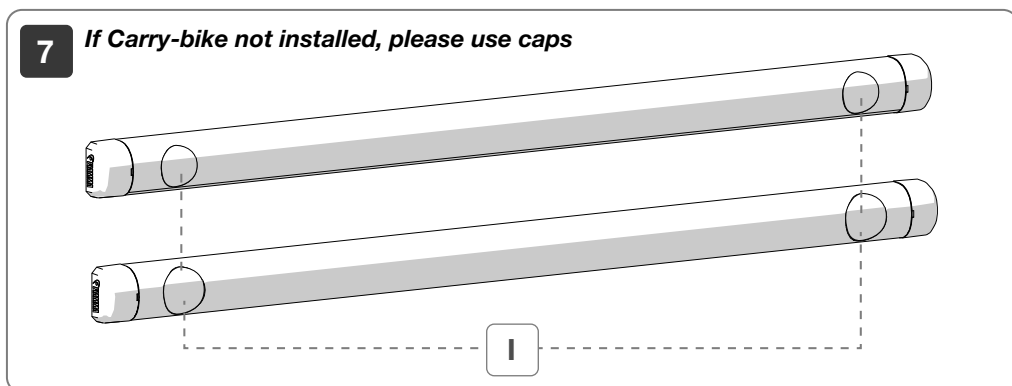
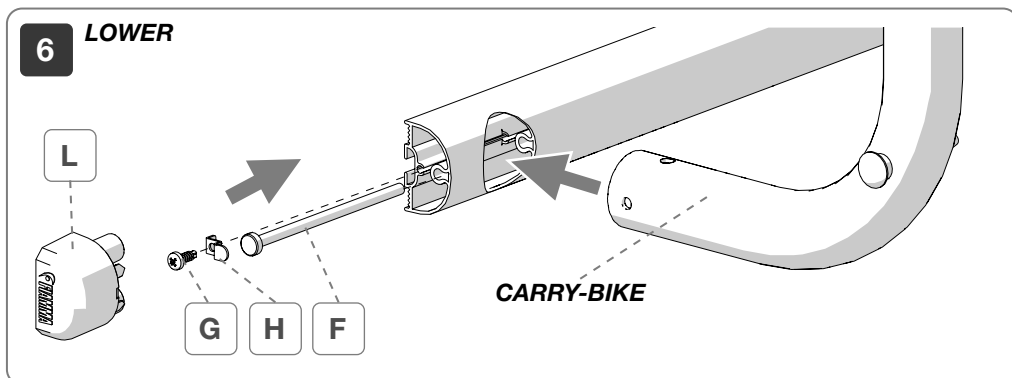

EN Fiamma declines all responsibility for any personal injury and damage to property due to incorrect assembly or use of the product; it is suggested to keep the instructions inside the vehicle. The assembly of the product must be carried out according to the assembly instructions: the product must not be modified in any way.

Always comply with speed limits and the Highway Code. The speed should always be suitable to traffic conditions and transported load.

Check periodically the product to make sure it is firmly attached, especially during the first kilometers of after long trips.

In the event of an accident involving the vehicle and/or the product, ensure that the product has not been damaged. In the event of damage, contact your local retailer before moving the vehicle. Fiamma declines every responsibility for any modification of the product that may cause damage and/or injury to things and people.

DE Fiamma lehnt jede Verantwortung für Personen- oder Sachschäden, die durch falsche Anbringung oder unsachgemäßen Gebrauch des Produktes verursacht wurden, ab. Es ist ratsam, die Anleitungen im Fahrzeuginneren aufzubewahren. Das Produkt muss gemäß der Montageanleitung angebracht werden: das Produkt darf in keiner Weise verändert werden.

Immer die Geschwindigkeitsbegrenzungen und die Straßenverkehrsordnung beachten. Die Geschwindigkeit muss immer an die Verkehrs- und Beladungsverhältnisse des Fahrzeugs angepasst werden.

Prüfen Sie regelmäßig die Befestigung des Produktes, insbesondere nach einer ersten gewissen Fahrt und jeweils vor und nach einer längeren Fahrt.

Nach einem eventuellen Unfall, der das Fahrzeug bzw. Produkt betrifft, immer sicherstellen, dass das Produkt nicht beschädigt wurde. Im Falle von Schäden wende man sich vor der Benutzung des Fahrzeugs an den Händler. Fiamma lehnt jede Verantwortung für Veränderungen am Produkt ab, die zu Schäden und/oder Verletzungen an Sachen und Personen führen können.



FR Fiamma décline toute responsabilité en cas de dommages aux biens ou de lésions corporelles qui dériveraient d'un usage inapproprié de l'article. Conserver les notices à l'intérieur du véhicule. Respecter les consignes de montage contenues dans la notice; ne jamais apporter de modifications. Respecter les limitations de vitesse et le code de la route. La vitesse doit toujours respecter les conditions de circulation sur route et la charge transportée. Contrôler régulièrement l'état des éléments de fixation du produit, en particulier après avoir parcouru les premiers Km suivant l'installation et, à chaque occasion, avant et après les plus longs trajets. En cas d'accident impliquant le véhicule et/ou le produit, vérifier que le produit n'a pas été endommagé. Dans le cas contraire, contacter le concessionnaire avant de déplacer le véhicule. Fiamma décline toute responsabilité quant aux éventuelles modifications apportées au produit pouvant entraîner des dommages et/ou lésions aux choses et aux personnes.

ES Fiamma declina toda responsabilidad por cualquier lesión personal y daño a la propiedad causado por al montaje o el uso incorrecto del producto; se sugiere mantener las instrucciones dentro del vehículo. El montaje del producto debe llevarse a cabo según las instrucciones de montaje. El producto no debe modificarse de ninguna manera. Respetar siempre el límite de velocidad y las normas de circulación. La velocidad debe adecuarse al estado del tráfico y a la carga que se transporta. Controlar periódicamente el estado de fijación del producto sobretodo después de los primeros Kms y cada vez antes y después de los viajes más largos. En caso de accidente que afecte al vehículo o al producto, asegúrese de que el producto no haya sufrido daños. Si hay algún daño, póngase en contacto con su distribuidor local antes de mover el vehículo. Fiamma no se hace responsable de cualquier modificación del producto que pueda causar daños o lesiones a cosas y personas.

IT Fiamma declina ogni responsabilità per eventuali lesioni personali e danni alle cose dovute al montaggio oppure all'uso errato del prodotto; si suggerisce di custodire le istruzioni all'interno del veicolo. Il montaggio del prodotto deve essere eseguito rispettando le istruzioni di montaggio: il prodotto non deve essere modificato in alcun modo. Rispettare sempre i limiti di velocità e il codice della strada. La velocità deve sempre essere adattata alle condizioni del traffico e al carico trasportato. Controllare periodicamente lo stato di fissaggio del prodotto soprattutto dopo aver percorso i primi Km dal montaggio ed ogni volta prima e dopo i viaggi più lunghi. In caso di incidente riguardante il veicolo e/o il prodotto, assicurarsi che il prodotto non abbia subito danni. In caso di danno, contattare il rivenditore locale prima di spostare il veicolo. Fiamma declina ogni responsabilità per qualsiasi modifica del prodotto che possa causare danni e/o lesioni a cose e persone.

EN **Warranty Fiamma.** In case of defects with regards to materials and manufacturing, the customer is entitled to the warranty in accordance with local laws and regulations of the country in which the product was purchased.

DE **Garantie Fiamma.** Im Falle einer Mangelhaftigkeit der Ware, kann der Verbraucher unter den erforderlichen Voraussetzungen gegenüber dem Verkäufer von dem Garantieanspruch zu den festgelegten Bedingungen gemäss den lokalen Rechtsvorschriften Gebrauch machen.

FR **Garantie Fiamma.** En cas d'un défaut de conformité du produit, le consommateur pourra faire valoir ses droits de recours en garantie selon les modalités prévues par les dispositions légales locales, pour autant que les conditions de recours soient satisfaites.

ES **Garantía Fiamma.** En caso de fallos o defectos de material y de fabricación, el cliente puede hacer valer la garantía de acuerdo con las leyes y reglamentaciones del país en el que el producto haya sido comprado.

IT **Garanzia Fiamma.** In caso di difetto di conformità dei beni, il consumatore potrà far valere nei confronti del venditore la garanzia secondo le modalità previste dalle disposizioni di legge locali, ove ne ricorrono i presupposti.



M1_IS_98690M004_revE

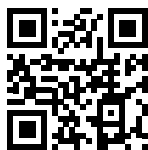

fiamma.com

Fiamma S.p.A. - Italy

Via San Rocco, 56
21010 Cardano al Campo (VA)



All rights reserved.

Fiamma S.p.A.

reserves the right to modify at any time,
without notice, prices, materials,
specifications and models or to cease
production of any model.